



ANALOG WATER TREATMENT CONTROLLER

MODEL ACT 102

INSTALLATION OPERATION MAINTENANCE INSTRUCTION

ACT@ FACTORY SERVICE POLICY

Your ACT™ controller is a state of the art electronic based unit. If you are experiencing a problem with your ACT™ controller, first consult the troubleshooting guide in your operation and maintenance manual. If the problem is not covered or cannot be solved, please contact our Technical Services Department for further assistance. Trained technicians are available to diagnose your problem and arrange a solution. Solutions may include purchase of replacement parts or returning unit to the factory for inspection and repair. All returns require a Return Authorization number to be issued by Pulsafeeder. Parts purchased to correct a warranty issue may be credited after an examination of original parts by Pulsafeeder. Warranty parts returned as defective which test good will be sent back freight collect. No credit will be issued on any replacement electronic parts.

Any modifications or out-of-warranty repairs will be subject to bench fees and costs associated with replacement parts.

ACT@ WARRANTY

Pulsafeeder, Inc. warrants ACT™ control systems of its manufacture to be free of defects in material or workmanship. Liability under this policy extends for 24 months from date of shipment. The manufacturer's liability is limited to repair or replacement of any failed equipment or part which is proven defective in material or workmanship upon manufacturer's examination. This warranty does not include removal or installation costs and in no event shall the manufacturer's liability exceed the selling price of such equipment or part. The manufacturer disclaims all liability for damage to its products through improper installation, maintenance, use, or attempts to operate such products beyond their functional capacity, intentionally or otherwise, or any unauthorized repair. The manufacturer is not responsible for consequential or other damages, injuries, or expense incurred through the use of its products.

The above warranty is in lieu of any other warranty, whether expressed or implied. The manufacturer makes no warranty of fitness or merchantability. No agent of ours is authorized to provide any warranty other than the above.

FCC WARNING

This equipment generates and uses radio frequency energy. If not installed and used properly, in strict accordance with the manufacturer's instructions, it may cause interference to radio communications. Operation of this equipment in a residential area is likely to cause interference in which case the user, at his own expense, will be required to take whatever measures necessary to correct the interference.



ANALOG WATER TREATMENT CONTROLLER

MODEL ACT 102

CONTENTS

1. INTRODUCTION 3

2. INSTALLATION 4

3. OPERATION 8

4. ELECTRODE REMOVAL, CLEANING AND REINSTALLATION 11

5. MAINTENANCE 12

6. TROUBLE SHOOTING GUIDE 13

7. ENCLOSURE DIAGRAM AND PARTS LIST 14

8. FLOW ASSEMBLY DIAGRAM AND PARTS LIST 15

9. ACT SERIES LINE UP AND OPTIONS BACK COVER

1. INTRODUCTION

The Pulsafeeder ACT Controllers are used to control chemical feed systems that continuously protect water cooling systems from the harmful effects of scaling and corrosion. They are designed using the latest technology .

The units are very accurate and easy to use. This simplified design provides automated control at an economic cost.

The ACT Series comes standard with electrical receptacle cords for blow down and metering pump activation.

2. INSTALLATION

Fig. 1, Typical Installation Diagram

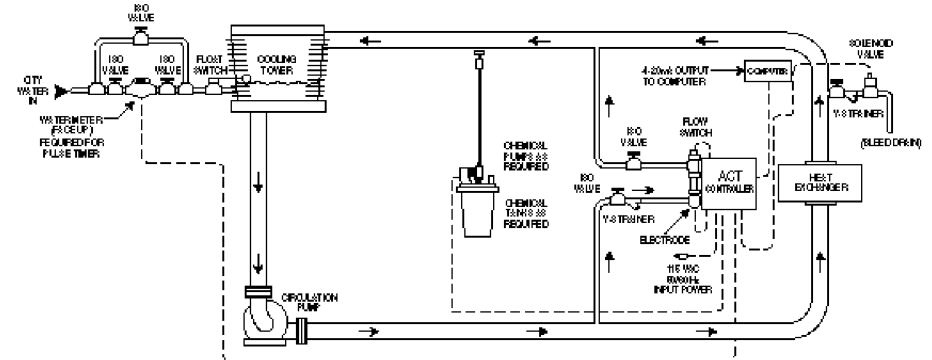

NOTE: NOT ALL EQUIPMENT SHOWN IS PROVIDED WITH ACT™ CONTROLLER, AND IS FOR REFERENCE ONLY.

A. LOCATION:

The ACT Series Controllers are completely prewired for ease of installation. Select a mounting location convenient to electrical and plumbing connections and easily accessible by the operator for cleaning and maintenance. The enclosure is corrosion resistant and will stand up to most industrial environments. Be sure unit is free from vapors and liquid spills. (Refer to Fig. 1, Typical Installation Diagram)

Fig. 2, Controller Dimensions

B. MOUNTING:

Mount Controller vertically on a wall or a permanent vertical support with adequate lighting and at a comfortable level. (Refer to Fig. 2, Controller Dimensions)

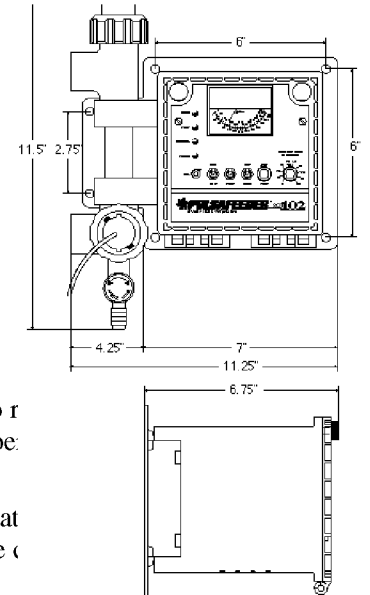

C. PLUMBING:

A flow rate of at least 1 gpm (gallons per minute) at the electrode is required for proper operation.

Install hand valves on both sides of electrode to reduce pressure at the electrode for easy removal and maintenance.

Make sure electrode flow assembly is installed at point before chemical injection point and where chemical and water are thoroughly mixed.

CAUTION: Do not inject chemical up stream of probe or sensors. This will cause inaccurate readings at the controller.

Direction of flow should be from bottom to top of mounted flow assembly (if utilized). Take time to review Fig. 1, Typical Installation Diagram, and note locations of hand valves, Y-strainers, etc. for proper operation and maintenance of all components in the system loop.

D. ELECTRICAL:

The ACT controller has been configured to physically separate the low and high voltage connections. Install according to IEC 1010 Clause 6.

Always use caution when making any electrical connection. Follow all applicable electrical codes. The supply power should be disconnected at the main before making any (low or high voltage) connections.

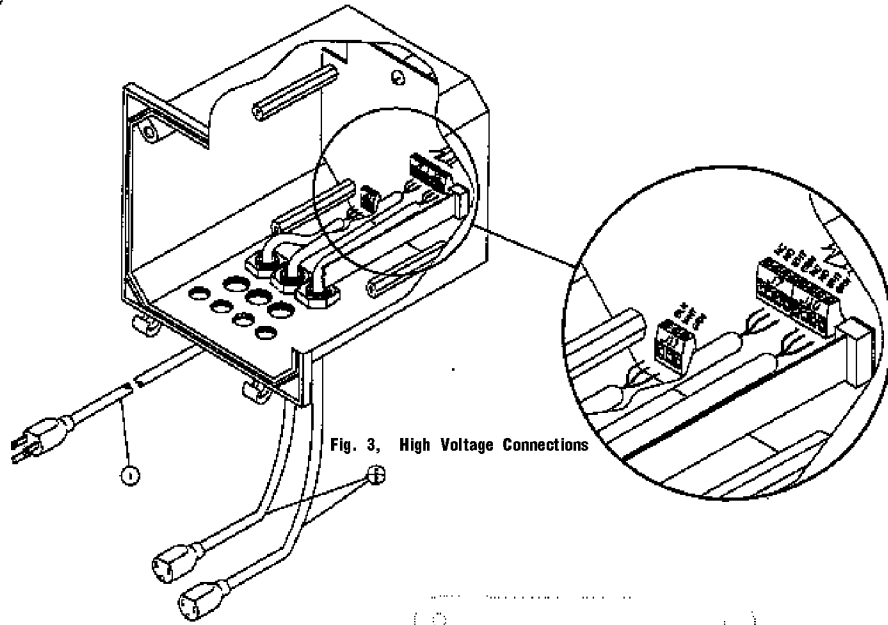

Fig. 3, High Voltage Connections

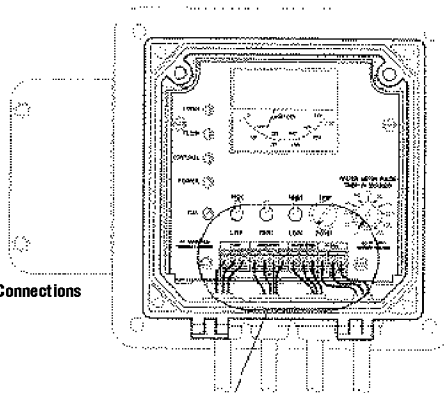
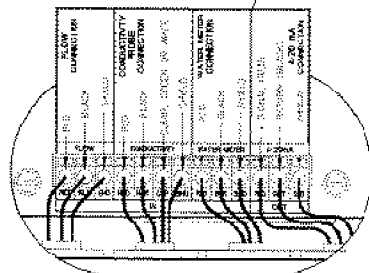

Fig. 4, Low Voltage Connections



1) High Voltage Connection

Please refer to Fig. 3, High Voltage Connections. ACT controllers come standard with pre-wired 6 ft., 18 AWG, 3-wire grounded power cord and two clearly marked 18 AWG, 3-wire receptacle cords for controlling external devices.

Conduit: Units ordered with Option A (Conduit) must be wired by the customer in accordance with all applicable electrical codes (i.e., NEC). When maximally loaded, the unit will draw 10.5 Amps. Each relay is capable of supplying 5 Amps. Size wiring accordingly.

Connections: Connect the supply and loads per the following convention:

Circuit Designator	Connection Type
HOT or NO/NC	Line
RET	Return
	Ground

Connect Supply Power to J11. Connect Load #1 - controlled by conductivity - to J7 (e.g., Blow-down solenoid valve) and Load #2 - controlled by the timer - to J10 (e.g., chemical metering pump). Load connections can be configured to supply power in the “Normally Open” or “Normally Closed” state by attaching the Line wire to the terminal labeled NO and NC respectively.

2) Low Voltage Connection

Please refer to Figure 4, Low Voltage Connections. Generally, low voltage wires are color coded to the designators printed on the front overlay. Make these connections after making the high voltage connections and re-assembling the panel to the front of the unit.

The insulation on the low voltage wires is stripped back approximately .25 inches at the factory. To attach, depress and hold the orange tab above the socket while inserting the stripped lead. Release the orange tab and pull gently on the wire to seat it in the connector and confirm that the wire is secure.

Note: Be careful not to push the wire too far into the socket such that the insulation is clamped by the connector.

Flow Sensor: Typically 22 AWG, 2 conductor shielded cable. The flow sensor wires are color coded as follows:

Label Designator	Function	Sensor Wire Color
RED	Sensor +	Red
BLK	Sensor -	Black
SHD	Probe Wire Shield	Silver (no insulation)

Conductivity Probe: Typically 22 AWG, 3 conductor shielded. The conductivity probe wires are color coded as follows. The probe cable length must be 3 meters or less with V1 option.

Label Designator	Function	Probe Wire Color
RED	Probe +	Red
BLK	Probe -	Black
CLR	Probe Temp. Comp	Clear, Green or White
SHD	Probe Wire Shield	Silver (no insulation)

Water Meter: Typically 22 AWG, 2 conductor shielded. The water meter wires should be connected as follows (user supplied wire may vary from that shown below):

Label Designator	Function	Water Meter Wire Color
RED	Probe +	Red
BLK	Probe -	Black
SHD	Wire Shield	Silver (no insulation)

4-20mA: Typically 22 AWG, 2 conductor shielded. The 4-20mA loop should be wired as follows (user supplied wire may vary from that shown below):

Label Designator	Function	4-20mA Loop Wire Color
SIG	4-20mA Loop (Signal)	Red
RET	4-20mA Loop (Return)	Black
SHD	Wire Shield	Silver (no insulation)

3. OPERATION

A. CONTROLS:

Refer to Fig. 5, Front Panel Diagram and familiarize yourself with the controls of your ACT unit.

Timer LED: Indicates when timer relay is active. Chemical pump relay is active.

Flow LED: Indicates when lit (on units equipped with mounted flow switch, Option B) that flow is present across flow assembly.

Control LED: Used during electrode calibration and to indicate conductivity trip point has been reached. Blow down solenoid relay is active.

Power LED: Indicates unit is plugged in and power is present on the circuit board.

Cal: Calibration adjustment knob used to calibrate unit conductivity.

High/Low Switch: Used to select range viewed on analog meter. Either 0-2500 $\mu\text{S}/\text{cm}$ or 0-5000 $\mu\text{S}/\text{cm}$ can be selected.

Test Switch: Activates all externally connected electrical devices to check for proper operation. Resets optional timer.

Set/Read Switch: Set position is used to set trip point. Read position is used to monitor conductivity as measured at the electrode.

Trip Point Knob: Also referred to as “set” or “control” point. With Set/Read Switch in “Set” position, use the Trip Point knob and refer to the analog scale to set desired “trip” point to activate bleed and feed.

Lock-Out Timer Knob, Option C (or Pulse Timer Knob if unit is equipped with Option D): Used to set the amount of time chemical pump operates during each bleed cycle (Option C) or each water meter pulse (Option D).

Analog Scale: Used to monitor system conductivity and for calibration.

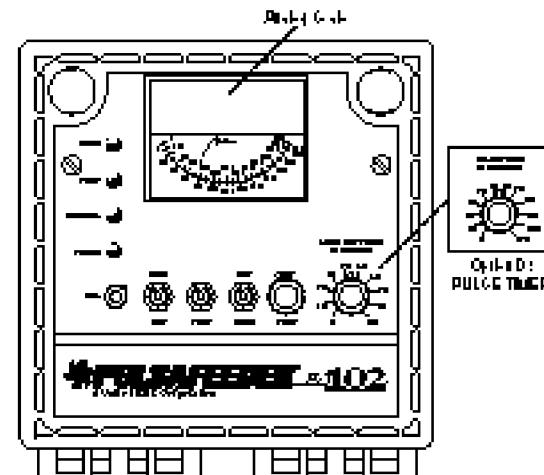

Fig. 5, Front Panel Diagram (cover in place)

B. CALIBRATION

1) Make sure unit is mounted properly and all plumbing and electrical connections are secure. Apply power to the unit and depress the test switch to confirm proper operation of the controller and relays.

2) Take a sample of the cooling water and measure with calibrated hand held meter. Note reading (See Fig. 6, Steps 2a and 2b).

3) Position Set/Read Switch in the "Read" position (See Fig. 7, Step 3).

4) Set the scale switch to either the high (5000 $\mu\text{s}/\text{cm}$) or Low (2500 $\mu\text{s}/\text{cm}$) setting (See Fig. 7, Step 4).

NOTE: The low scale if applicable, provides more resolution.

NOTE: The scale used for calibration must be the same as that to be used for control.

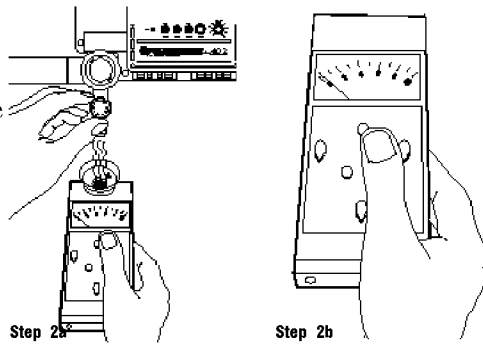

Fig. 6, Water sample reading

5) Adjust Cal Adjust knob until the meter on ACT matches the reading on the calibrated hand held meter. Your unit is now calibrated (See Fig. 7, Step 5).

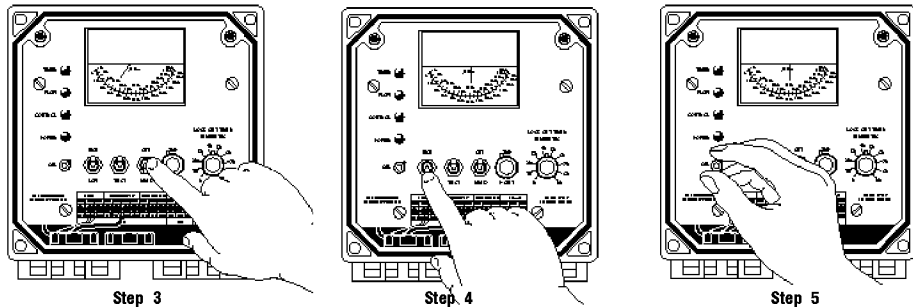

Fig. 7, System Calibration

C. SETTING CONDUCTIVITY TRIP POINT

1) With Set/Read Switch in "Set" position, turn Trip Point Knob to position needle on analog scale to desired trip point (See Fig. 8, Step 1).

2) Return the Set/Read Switch to "Read" (See Fig. 8, Step 2).

NOTE: All standard ACT units have a differential control that has been factory set to approximately 6% of the Trip Point. This important feature prevents @hattering@ (the rapid on-off switching of the relay when system conductivity hovers near the trip point).

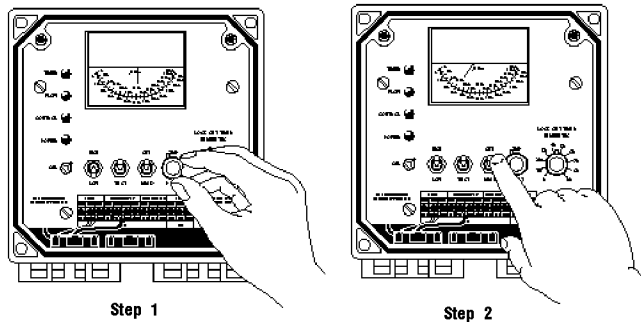

Fig. 8, Trip Point Setpoint

D. LOCK-OUT TIMER (OPTION C)

Turn Lock-Out Timer Knob to limit the length of time feed pump is to operate (from 0-90 minutes) during each bleed cycle (See Fig. 9).

NOTE: If lock-out time is set to @,@ pump will operate continuously as long as there is a bleed condition.

NOTE: If bleed condition is satisfied before time limit has expired, the lock-out timer shuts off feed device and fully resets for the next cycle.

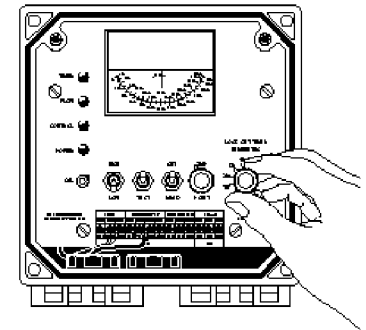

Fig. 9, Adjusting Timer (Option C shown).

E. WATER METER PULSE TIMER (OPTION D)

The Water Meter Pulse Timer monitors a switch closure generated by a water meter or other "dry contact" type device. Upon detection, the control activates the chemical feed pump for a specified time period. The connection is made through the "Water Meter" low voltage connection block. Refer to Fig. 4, pg. 5, for wiring.

NOTE: The water meter must ONLY perform a @dry contact@ switch closure. It must NOT generate any voltage signal, and must be insulated from earth ground. Failure to observe this precaution will damage the controller and void the warranty.

NOTE: If the Pulse Timer option (D) is installed but unused, disconnect all equipment from the Load #2 output and set the timer to 0.

Turn the Pulse Timer Knob to adjust the length of time the feed pump is to operate (from 0-150 seconds). The water meter switch closure will cause the chemical feed pump to operate for the desired interval.

NOTE: If the interval between switch closures is less than the interval specified by the setting knob, the pump will run continuously. If the interval is set to 0, the pump will not operate.

F. 4-20mA PROPORTIONAL OUTPUT (OPTION M)

The isolated 4-20mA Proportional Output is designed to interface with an analog recorder, metering pump, or computer. The output tracks the system water conductivity. The controller is factory calibrated for 4-20mA operation. Non-standard calibration of signal is achieved by adjusting the Off-set (labeled R7) and Gain (labeled R9) potentiometers. See Figure 10. The linearity potentiometer (labeled R12) should not be adjusted.

Fig. 10, 4-20mA Calibration Pots

4. ELECTRODE REMOVAL, CLEANING, AND REINSTALLATION

A. REMOVING THE ELECTRODE

- 1) Remove power from the system.
- 2) Remove pressure by shutting hand valves on both sides of the flow/electrode assembly (refer to Fig. 1, Typical Installation Diagram, pg. 4).
- 3) Open "sample" valve. This will help removal of the electrode.
- 4) Unscrew couplings with tabs on electrode housing, grip coupling ring and remove electrode by pulling straight out. (See Fig. 11, Electrode)

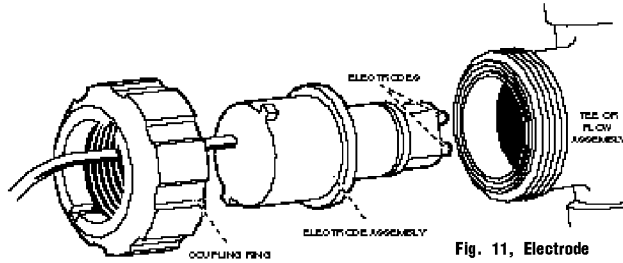

B. CLEANING ELECTRODE

- 1) Wipe the electrodes with a clean cloth. It is important to be sure to wipe the sides of the electrodes as well as the ends.
- 2) Use fine grain emery cloth for stubborn stains
- 3) Some fouled electrodes might require dipping in a mild solution of muriatic acid to remove fouling.

NOTE: Always observe proper handling procedures when working with acids.

C. REINSTALLING ELECTRODE

- 1) Electrode is keyed and will only go one way into tee assembly.
- 2) Gently push electrode in to position until it fits snug in housing.
- 3) Hand tighten coupling ring only.
- 4) Close sample valve and open hand valves to reapply pressure to the flow assembly.

NOTE: Open hand valves slowly to avoid water hammer.

- 5) Reapply power to the system and re-calibrate unit.

5. MAINTENANCE

A. SET UP A MAINTENANCE PROGRAM FOR YOUR CONTROLLER.

Normally, the electronic circuitry in the controller will not require maintenance. However, ambient temperature, humidity changes, and aging can affect the calibration of the controller. Electrodes will become dirty over a period of time and will require cleaning. The frequency of cleaning depends on the installation and the water that comes in contact with the electrode.

During the first few months of operation, check the electrode each week. This allows you to determine how often to clean the electrode. After the first few months of operation, you will be able to establish a proper maintenance schedule for your system. Check the electrode and controller calibration at least once every two months. The more frequent the maintenance, the more assurance you have of reliable controller performance.

By observing readings before and after electrode cleaning, you can determine how often to clean the electrode. If no change or only a small change in readings occurs, clean the electrode less often. If a large change in readings occurs, clean the electrode more often. See Cleaning the Electrode on page 11 of this manual.

B. ACCURACY AND READINGS

The conductivity of any solution changes with the temperature of that solution. The ACT Controllers are compensated to 20°C (63°F). In most water solutions, temperature changes affect the conductivity by about 1% per degree Fahrenheit from ambient.

Temperature compensation is effective across a range of 7.2° to 40.6°C (45° to 105°F). The electrode should read consistent with any accurate temperature compensated test instrument.

6. ENVIRONMENT

The operating environment of your controller is -25°C to 55°C, 5% to 100% relative humidity, and 0.028 max moisture Kg/Kg dry. (ISA82 Class C2).

7. TROUBLE-SHOOTING GUIDE

SYMPTOM	POSSIBLE CAUSE	SOLUTION
Power light is not on	Blown fuse	Replace fuse with 1/2 amp/250V Wickman19372-041K
	No power supplied to unit	Check line circuit breaker. Fuse is "T" type.
Fuse blows repeatedly	External component defective	Disconnect external loads. If this prevents the fuse from blowing, plug each external load in, one-by-one, until the fuse blows. Repair or replace defective component. Wickman 19372-063K
	Pump current requirements too great	Maximum 5 amp resistive. Use a motor contactor to control the pump motor. Fuse is "T" type.
Control light stays on	Conductivity of water sampled is beyond range of controller	Check the conductivity of the water with a conductivity tester and compare readings.
	Conductivity probe leads shorted	Unplug probe leads, light should go off. Check lead for shorts.
	Solenoid Valve plugged - no bleed off	Clean or replace solenoid valve.
	Insufficient or no flow past electrode.	Remove obstruction in sample line.
Control light does not come on	Overflowing or leaking system	Solenoid valve not closing.
Control light goes on and off every few minutes	Electrode is airbound	Bleed air from electrode by allowing water to completely fill and flow through it to drain.
	Poor circulation through conductivity electrode	Clean electrode.
	Bleed rate exceeds make-up water rate	Decrease bleed rate.
Wide variation in solution	Bleed rate too low	Increase bleed rate.
	Electrode fouled or dirty	Clean or replace electrode.
	Bleed rate too low	Increase bleed rate.
Bleed-off solenoid or other electrical device being operated by the controller does not operate.	Inoperative solenoid valve	Replace valve coil or valve as required.
	Wiring between solenoid	Rewire this connection. To check solenoid valve and control defective valve, disconnect it from the controller and energize it from a separate power source.
	Improper voltage	Check for correct valve coil voltage; should be 115 VAC. (Optional 220 VAC.)
	Improper pressure differential across solenoid valve	Check piping and pressure at your location to make sure at least the minimum pressure exists across your solenoid.
	Blown Fuse	Replace fuse F2/F3 with 5 amp/250VAC.
Abnormal reading	Electrode fouled or dirty	Use this method to determine if the electrode is at fault. Activate the TEST Switch. The Control light should come on and all external relays should be energized (the chemical pump, solenoid valve, and/or other electrical controlled devices should be operating). If the unit has been previously recalibrated, the value read should be that which was used and recorded at that time.

8. ENCLOSURE DIAGRAM AND PARTS LIST

ITEM	QUAN.	DESCRIPTION
19	REF.	POWER CORD FEMALE 115V
18	REF.	
17	REF.	
16	REF.	
15	REF.	
14	REF.	
13	REF.	
12	REF.	
11	REF.	
10	REF.	
9	REF.	
8	REF.	
7	REF.	
6	REF.	
5	REF.	
4	REF.	
3	REF.	
2	REF.	
1	REF.	

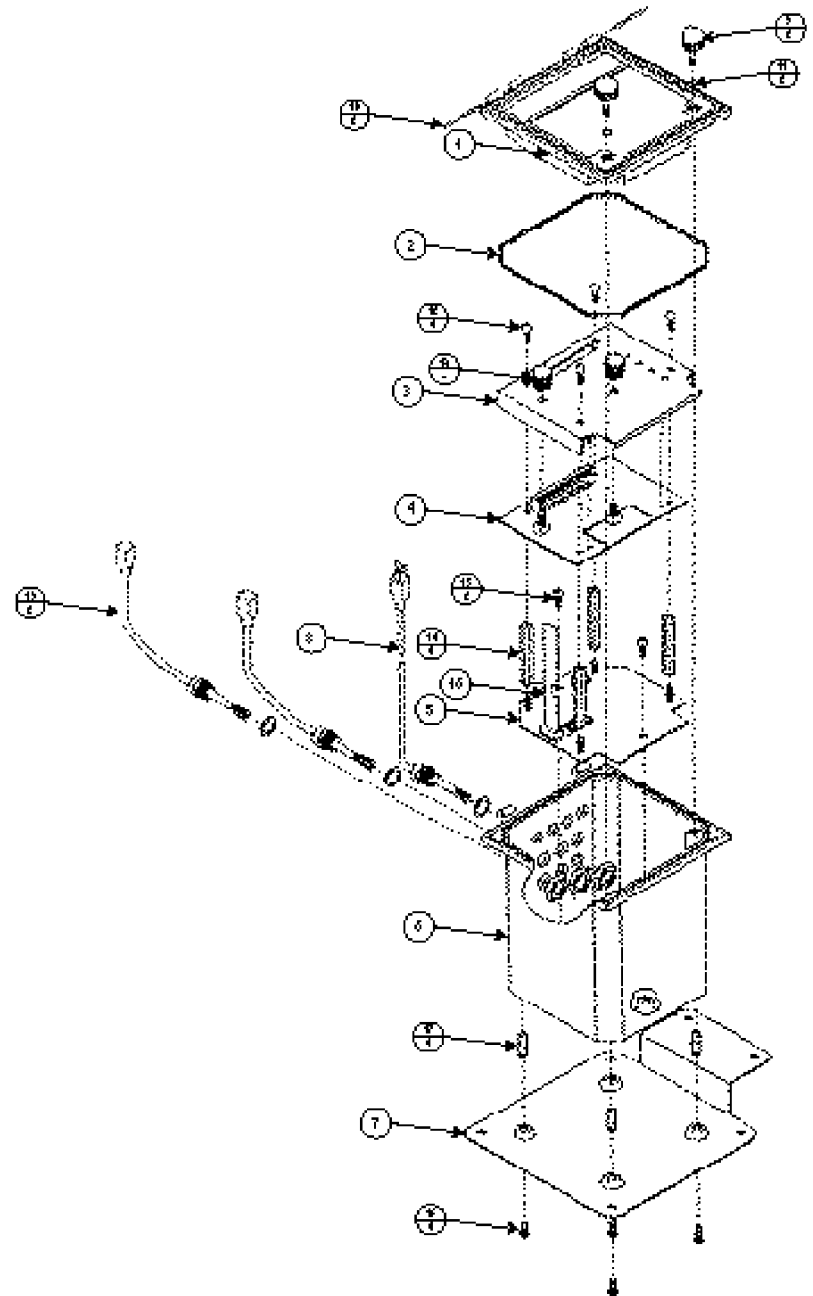

9. FLOW ASSEMBLY DIAGRAM AND PARTS LIST

ITEM	QUAN.	SALES PART#	PART #	DESCRIPTION
19	1	N/A	20-110-02	CAUTION TAG, PVC ADAPTERS
18	2	PX01	03-093-00	3/4 MALE ADAPTER, PVC
17	1	CN-TP	04-300-34	PROBE ASSY,T-PLUS,3@EMP/CN
16	1	PX02	04-300-08	VALVE ASSEMBLY, SAMPLE
15	1	PX03	06-189-02	PLUG, .25 NPT
14	1	PX04	03-096-62	ELBOW/TEE
13	1	PX05	03-096-71	NIPPLE, .75 NPT X 3.00
12	2	PX06	06-189-00	CLAMP, PIPING
11				
10	2	PX08	06-176-00	SCREW, 10-32 X 1
9	2	PX09	06-164-00	LOCKWASHER, #10
8	2	PX10	06-165-00	WASHER, FLAT, #10
7	1	PX11	06-008-36	SPACER, FLOW ASSEMBLY
6	2	PX12	03-096-52	CLEAR TEE, FLOW
5	1	PX13	03-005-04	GASKET, O-RING #2-029
4	2	PX14	04-300-14	SHUTTLE ASSEMBLY
3	1	PX15	03-005-02	GASKET, O-RING #2-119
2	2	PX16	04-300-12	FLOW SWITCH CAP
1	1	PX17	06-008-00	NUT, COUPLING, 2-6

SPARE PARTS LIST:				
ITEM	SALES PART #	PART #	DESCRIPTION	
ELECTRODE	CN-TP	CN-TP	CONDUCTIVITY ELECTRODE ASSEMBLY 30"	
F1	AAMP1	12-042-80	LITTLE FUSE .5 AMP, 250V, 1/4 X 1-1/4, FAST BLOW	
F2, F3	AAMP5	12-042-82	LITTLE FUSE 5 AMP, 250V, 1/4 X 1-1/4, FAST BLOW	

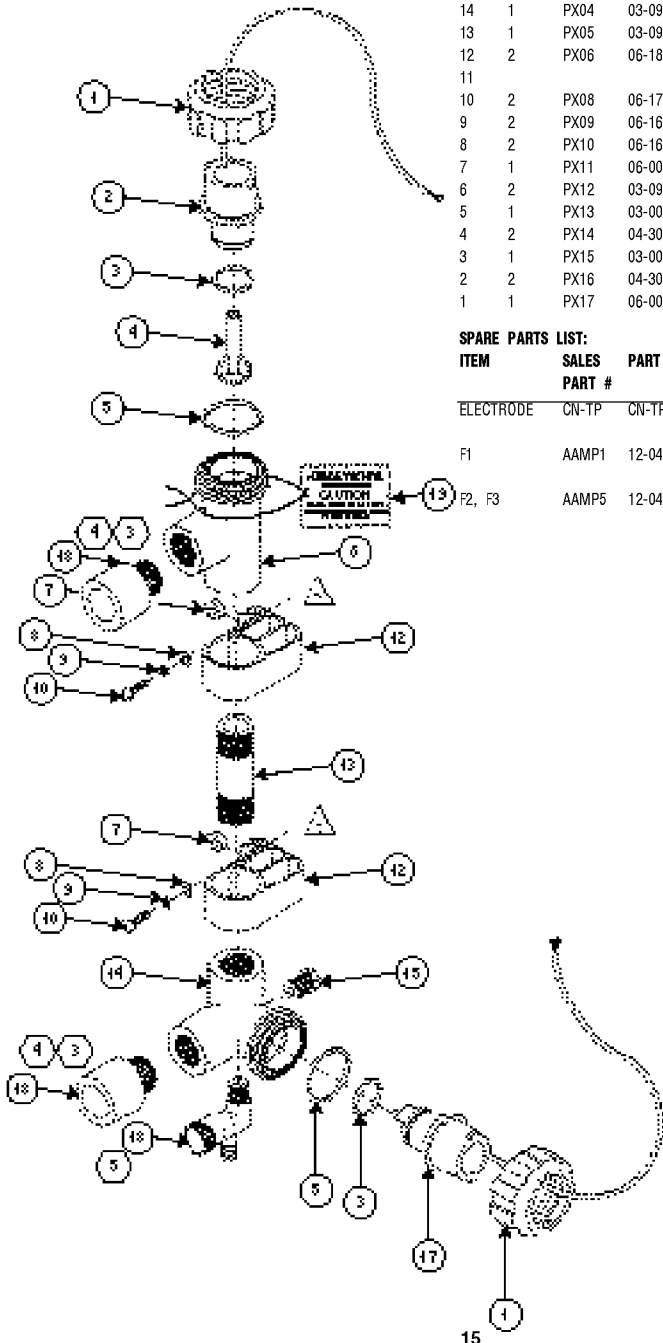

10. ACT COOLING TOWER CONTROLLER SERIES

A. KEY FEATURES:

- Front panel calibration.
- Front panel dial set point.
- Conductivity range 0-2,500 or 0-5,000 $\mu\text{S}/\text{cm}$.
- Blow down and or metering pump indicator LED.
- Relay test switch.
- Power indicator LED.
- Pre-wired output connections (conduit optional).
- Weather-tight enclosure designed to NEMA 2 and NEMA 4X, option A only.
- Wall mountable.

B. ACT MODEL STANDARD FEATURES:

ACT 50	Dial conductivity controller 0-5,000 $\mu\text{S}/\text{cm}$
ACT 101	Dial conductivity controller, selectable dual scale 0-2,500 $\mu\text{S}/\text{cm}$ and 0-5,000 $\mu\text{S}/\text{cm}$
ACT 102	Analog meter conductivity controller, selectable dual scale 0-2,500 $\mu\text{S}/\text{cm}$ and 0-5,000 $\mu\text{S}/\text{cm}$

C. OPTIONS:

		SERIES AVAILABLE
A	Conduit	50/101/102
B	Mounted flow switch	101/102
C	Lockout timer	101/102
D	Pulse timer	101/102
M	4-20 mA Isolated output	101/102
P	230 VAC @ 50/60 Hz service (requires option A)	50/101/102
V	ETL	101/102
V1	CE	101/102
W	Private Label	50/101/102

PULSAFEEDER[®]
A Unit of IDEX Corporation

27101 Airport Road
Punta Gorda, FL 33982

Toll free: 1-800-333-6677
Phone: 1-941-575-3800
Toll free Fax: 1-800-456-4085
Fax: 1-941-575-4085